



BV2X - AISI 316L Stainless steel calorifier with two removable heat exchangers

AISI 316L Stainless steel calorifier designed for the production and storage of domestic hot water (DHW). The tank is equipped with two AISI 316L stainless steel U tube bundle removable heat exchangers. The lower heat

exchanger is bent down in order to avoid the growth of bacteria in the coldest part of the cylinder. Cylinders are also prepared to host a backup immersion heater (not supplied).

HEAT SOURCE



APPLICATION



TECHNICAL FEATURES

DHW cylinder

Heat exchanger

General features

Material	AISI 316L Stainless steel (1.4404)
Internal protective treatment	Pickling and passivation
External protective treatment	Pickling and passivation
Rating (P max. / T max.)	6 bar / 95°C
Cathodic protection	Magnesium anode
Material	AISI 316L Stainless steel (1.4404) over a stainless steel plate
Internal protective treatment	Pickling and passivation
External protective treatment	Pickling and passivation
Type	U tube bundle expanded over a removable plate
Rating (P max. / T max.)	10 bar / 95°C
Capacity	200 - 5000 L
Warranty	5 years (DHW cylinder) - 2 years (heat exchanger)
Insulation	- Soft insulation with polyester + PVC: Fire retardant class B2 (DIN 4102) - Hard insulation: - up to 2000 L with polyurethane foam + PVC: Fire retardant class B3 (DIN 4102) - from 2500 to 5000 L with polyester (15 mm) + polystyrene (85 mm) + PVC: Fire retardant class B2 (DIN 4102)

In compliance with

- Pressure Equipment Directive (PED) 2014/68/UE Art. 4 Para 3
- Italian MOH specifications (products suitable to contain potable water)
- Energy related Products (Erp) Directive 2009/125/CE

ACCESSORIES (page 218)



Impressed current electronic anode



Electronic control unit



Thermostat



Thermometer

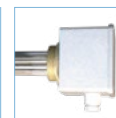

1 1/2 electric immersion heater

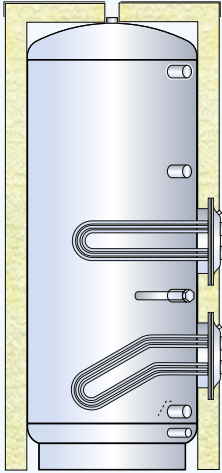

BV2X - Hard insulation and PVC jacket

CODE	INSULATION THICK. (mm)	ErP CLASS	HEAT LOSS S (W)	REAL CAPACITY (L)	LOWER HEAT EXCHANGER (m ²) / (L) *	UPPER HEAT EXCHANGER (m ²) / (L) *
BV2X 00200 R	50	C	65,7	193,1	0,50 / 2,6	0,50 / 2,6
BV2X 00300 R	50	C	77,2	293,6	0,75 / 4,3	0,75 / 4,3
BV2X 00500 R	50	C	89,6	503,6	1,00 / 6,1	1,00 / 6,1
BV2X 00800 R	100	C	119,7	760,5	2,00 / 10,4	1,50 / 6,6
BV2X 01000 R	100	C	123,6	942,2	3,00 / 15,7	2,00 / 10,4
BV2X 01500 R	100	C	142,6	1483,6	3,00 / 15,7	3,00 / 15,7
BV2X 02000 R	100	C	157,4	1967,2	4,00 / 21,7	4,00 / 21,7
BV2X 02500 R	100	-	-	2510,7	5,00 / 27,4	4,00 / 21,7
BV2X 03000 R	100	-	-	2974,7	6,00 / 33,1	5,00 / 27,4
BV2X 04000 R	100	-	-	3911,6	8,00 / 42,9	8,00 / 42,9
BV2X 05000 R	100	-	-	5022,4	10,00 / 51,5	10,00 / 51,5

 CALORIFIERS WITH
 REMOVABLE HEAT
 EXCHANGERS

BV2X - Soft insulation with polyester and PVC jacket

CODE	INSULATION THICK. (mm)	ErP CLASS	HEAT LOSS S (W)	REAL CAPACITY (L)	LOWER HEAT EXCHANGER (m ²) / (L) *	UPPER HEAT EXCHANGER (m ²) / (L) *
BV2X 00800 F	130	C	134,1	760,5	2,00 / 10,4	1,50 / 6,6
BV2X 01000 F	130	C	144,4	942,2	3,00 / 15,7	2,00 / 10,4
BV2X 01500 F	130	C	170,5	1483,6	3,00 / 15,7	3,00 / 15,7
BV2X 02000 F	130	C	188,3	1967,2	4,00 / 21,7	4,00 / 21,7
BV2X 02500 F	100	-	-	2510,7	5,00 / 27,4	4,00 / 21,7
BV2X 03000 F	100	-	-	2974,7	6,00 / 33,1	5,00 / 27,4
BV2X 04000 F	100	-	-	3911,6	8,00 / 42,9	8,00 / 42,9
BV2X 05000 F	100	-	-	5022,4	10,00 / 51,5	10,00 / 51,5

* Volume occupied by the heat exchanger and its support structure

200-1500 L

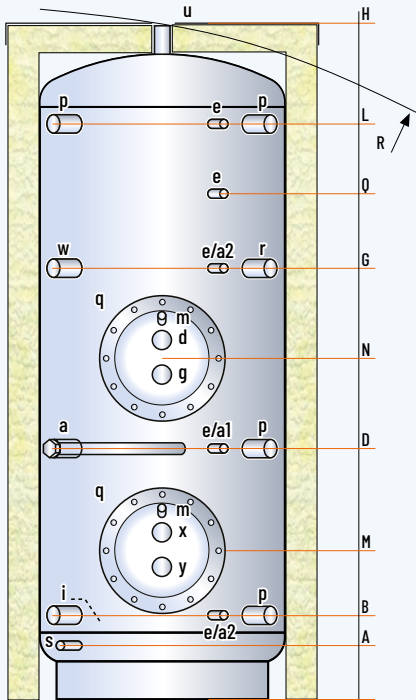

LEGEND

- a . Magnesium anode
- a1-a2. Opening for electronic anode
- d . Boiler flow
- e . Thermometer - Sensor
- g . Boiler return
- i . Domestic cold water inlet
- m. Heat exchanger vent
- p . Free connection
- q . Heat exchanger flange
- r . Recirculation
- s . Drain
- u . Domestic hot water outlet
- x . Solar system flow
- y . Solar system return
- w . Opening for immersion heater

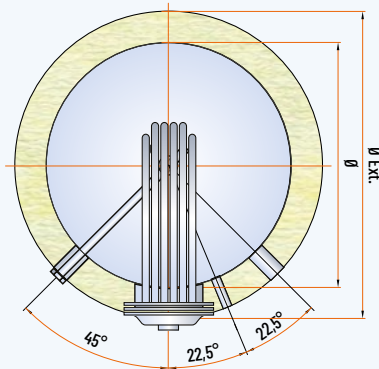

2000-5000 L

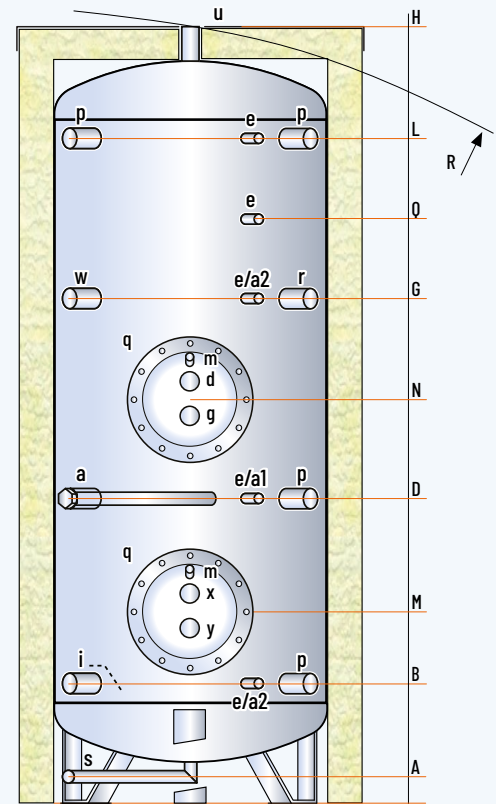

MODEL	DIMENSIONS (mm)		Ø EXT **	R *	LOWER HEAT EXCHANGER (m ²)	UPPER HEAT EXCHANGER (m ²)	Electronic anode (optional)	WEIGHT (kg)
	Ø	H	(Hard/Soft ins.)					
BV2X 00200 R	450	1305	550	1430	0,50	0,50	a1 (EPS 375/125)	78
BV2X 00300 R	500	1595	600	1720	0,75	0,75	a1 (EPS 375/125)	91
BV2X 00500 R	650	1645	750	1820	1,00	1,00	a1 (EPS 375/125)	110
BV2X 00800_	790	1750	990/1050	1745	2,00	1,50	a1 (EPS 375/125)	183
BV2X 01000_	790	2110	990/1050	2095	3,00	2,00	a1 (EPS 375/125)	213
BV2X 01500_	1000	2115	1200/1260	2145	3,00	3,00	a2 (EPS 375/125)	272
BV2X 02000_	1100	2465	1300/1360	2465	4,00	4,00	a2 (EPS 375/125)	348
BV2X 02500_	1200	2595	1400	2640	5,00	4,00	a2 (EPS 700/200)	404
BV2X 03000_	1250	2795	1450	2835	6,00	5,00	a2 (EPS 700/200)	458
BV2X 04000_	1400	2925	1600	2995	8,00	8,00	a2 (EPS 700/200)	648
BV2X 05000_	1600	2955	1800	3090	10,00	10,00	a2 (EPS 700/200)	748

* For capacities from 200 to 500 litres, the tilt height refers to the insulated cylinder
 ** The insulation is removable except for models from 200 to 500 litres

MODEL	HEIGHTS (mm)								CONNECTIONS (GAS)							
	A	B	D	G	L	M	N	Q	a p r	d g x y	e	i u	m	s	w	q
BV2X 00200 R	110	190	515	890	1075	350	785	975	1"¼	1"	½"	1"¼	¾"	1"	1"½	220/290
BV2X 00300 R	110	215	595	1080	1350	375	870	1215	1"¼	1"	½"	1"¼	¾"	1"	1"½	220/290
BV2X 00500 R	135	240	615	1105	1375	445	890	1240	1"¼	1"	½"	1"¼	¾"	1"	1"½	220/290
BV2X 00800_	170	275	655	1145	1410	450	970	1280	1"¼	2"	½"	1"½	¾"	1"	1"½	300/380
BV2X 01000_	170	275	810	1355	1755	455	1045	1555	1"¼	2"	½"	1"½	¾"	1"	1"½	300/380
BV2X 01500_	235	340	765	1400	1725	520	1080	1250	1"¼	2"	½"	2"	¾"	1"	1"½	300/380
BV2X 02000_	100	475	1010	1515	1975	655	1260	1645	1"¼	2"	½"	2"	¾"	1"	1"½	350/430
BV2X 02500_	100	505	1040	1600	2105	690	1290	1750	1"¼	2"	½"	2"	¾"	1"	1"½	350/430
BV2X 03000_	90	515	1100	1730	2300	675	1415	1880	1"¼	2"	½"	3"	¾"	1"	1"½	350/430
BV2X 04000_	120	595	1190	1815	2380	755	1505	1965	1"¼	2"	½"	3"	¾"	1"	1"½	350/430
BV2X 05000_	100	600	1185	1815	2385	825	1505	1965	1"¼	2"	½"	3"	¾"	1"	1"½	350/430

Disclaimer: this layout is purely indicative. It does not replace consultant's design

LEGEND

- | | | |
|---|-----------------------------|--------------------------------------|
| 1 . Domestic water expansion vessel | 5 . Pressure reducing valve | 9 . Solar system control unit |
| 2 . Domestic water drain | 6 . DWH Recirculation pump | 10 . Solar system safety kit (6 bar) |
| 3 . Domestic water safety valve (6 bar) | 7 . DHW 3-way valve | 11 . Solar system expansion vessel |
| 4 . Strainer | 8 . Vent with valve | |

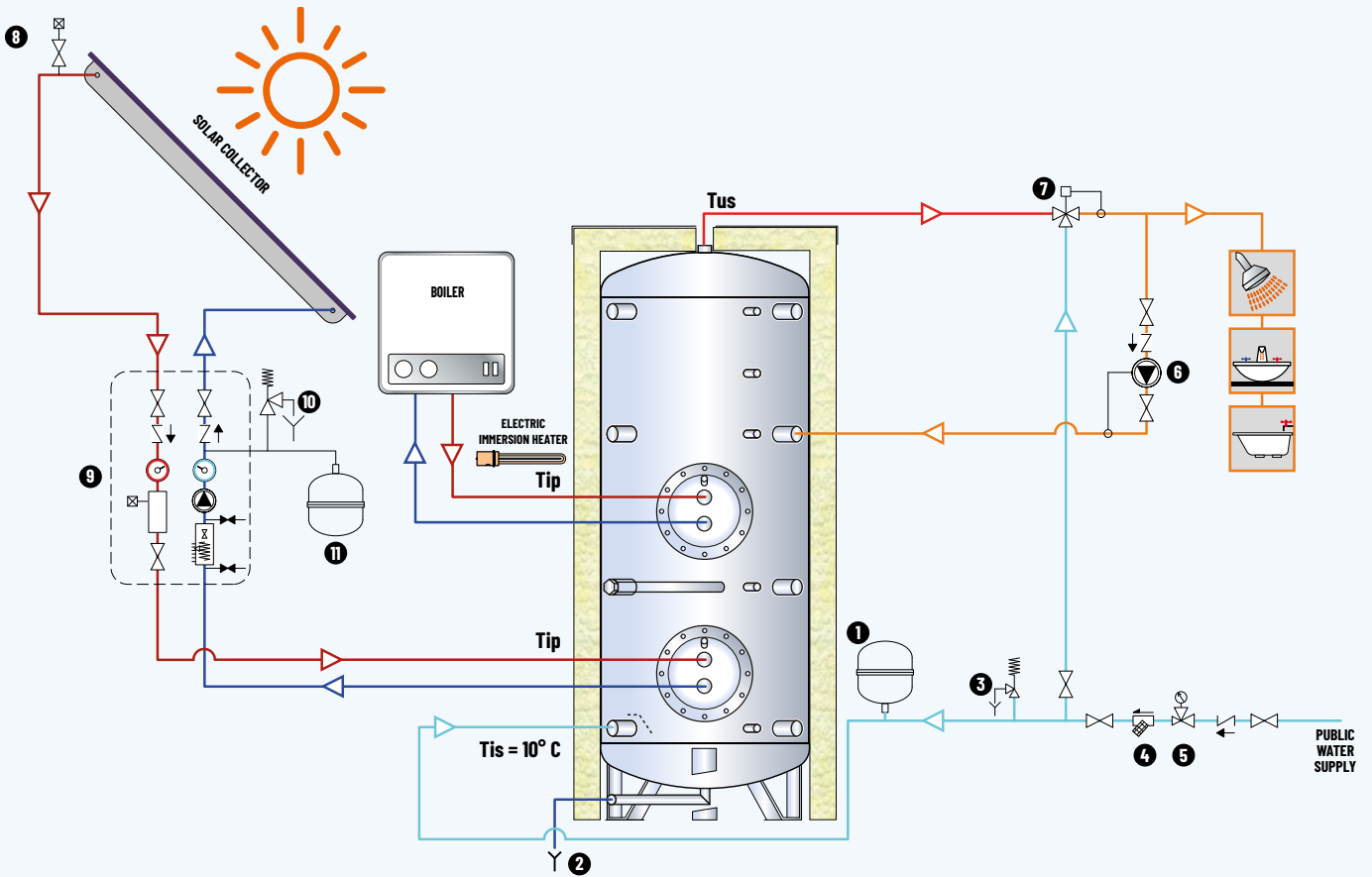

CALORIFIERS WITH
REMOVABLE HEAT
EXCHANGERS

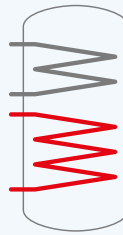

Data related to the lower heat exchanger

MODEL		BV2X 00200 R				BV2X 00300 R				BV2X 00500 R				BV2X 00800_			
	HEAT EXCHANGER (m ²) [L] ¹	0,5 [2,9]				0,75 [3,8]				1,0 [4,7]				2,0 [9,5]			
	PRIMARY FLOW (m ³ /h)	2				2				3				5			
	PRIMARY TEMP. (°C)	50	60	70	80	50	60	70	80	50	60	70	80	50	60	70	80
DHW FROM 10 TO 45 °C	LITRES 10' (L/10') ²	198	210	298	309	302	319	453	468	509	533	758	778	782	828	1176	1216
	LITRES FIRST HOUR ²	281	352	493	554	424	528	739	828	674	814	1142	1261	1108	1384	1936	2171
	CONTINUOUS DRAW (L) ³	105	180	246	310	155	264	361	455	208	355	485	611	412	702	960	1207
	POWER (kW)	4,3	7,3	10,0	12,6	6,3	10,8	14,7	18,5	8,4	14,4	19,8	24,9	16,8	28,6	39,1	49,1
	PREHEATING ³ (min)	112	65	47	37	117	68	49	39	149	86	63	50	114	66	48	38
DHW FROM 10 TO 60 °C	LITRES 10' (L/10') ²	-	-	201	209	-	-	305	317	-	-	515	531	-	-	793	824
	LITRES FIRST HOUR ²	-	-	297	346	-	-	447	519	-	-	705	801	-	-	1169	1358
	CONTINUOUS DRAW (L) ³	-	-	121	173	-	-	179	254	-	-	240	341	-	-	476	675
	POWER (kW)	-	-	7	10	-	-	10	15	-	-	14	20	-	-	28	39
	PREHEATING ³ (min)	-	-	96	67	-	-	100	70	-	-	128	90	-	-	98	69
NL ⁴	0,9				2				5				11				
MODEL		BV2X 01000_				BV2X 01500_				BV2X 02000_				BV2X 02500_			
	HEAT EXCHANGER (m ²) [L] ¹	3,0 [13,0]				3,0 [13,0]				4,0 [17,2]				5,0 [20,8]			
	PRIMARY FLOW (m ³ /h)	5				6				7				7			
	PRIMARY TEMP. (°C)	50	60	70	80	50	60	70	80	50	60	70	80	50	60	70	80
DHW FROM 10 TO 45 °C	LITRES 10' (L/10') ²	986	1054	1495	1553	1501	1568	2230	2287	1988	2077	2953	3029	2536	2646	3762	3855
	LITRES FIRST HOUR ²	1469	1875	2616	2961	1984	2390	3351	3696	2627	3161	4430	4883	3329	3989	5591	6151
	CONTINUOUS DRAW (L) ³	610	1038	1416	1779	610	1037	1416	1779	807	1368	1865	2342	1002	1697	2311	2900
	POWER (kW)	24,8	42,2	57,6	72,4	24,8	42,2	57,6	72,4	32,8	55,7	75,9	95,3	40,8	69,1	94,1	118,1
	PREHEATING ³ (min)	96	56	41	32	152	88	64	51	153	89	65	51	159	92	67	53
DHW FROM 10 TO 60 °C	LITRES 10' (L/10') ²	-	-	1001	1048	-	-	1516	1562	-	-	2008	2069	-	-	2560	2635
	LITRES FIRST HOUR ²	-	-	1559	1837	-	-	2073	2352	-	-	2745	3110	-	-	3474	3927
	CONTINUOUS DRAW (L) ³	-	-	705	997	-	-	705	997	-	-	931	1315	-	-	1155	1631
	POWER (kW)	-	-	41	58	-	-	41	58	-	-	54	76	-	-	67	95
	PREHEATING ³ (min)	-	-	83	58	-	-	131	91	-	-	132	92	-	-	136	96
NL ⁴	17				32				38				44				
MODEL		BV2X 03000_				BV2X 04000_				BV2X 05000_							
	HEAT EXCHANGER (m ²) [L] ¹	6,0 [24,8]				8,0 [31,4]				10,0 [34,3]							
	PRIMARY FLOW (m ³ /h)	10				12				15							
	PRIMARY TEMP. (°C)	50	60	70	80	50	60	70	80	50	60	70	80				
DHW FROM 10 TO 45 °C	LITRES 10' (L/10') ²	3009	3141	4466	4579	3960	4135	5878	6026	5079	5297	7531	7716				
	LITRES FIRST HOUR ²	3963	4759	6671	7346	5223	6271	8785	9673	6657	7967	11165	12275				
	CONTINUOUS DRAW (L) ³	1206	2044	2784	3495	1595	2698	3672	4606	1993	3372	4590	5758				
	POWER (kW)	49,1	83,2	113,3	142,3	64,9	109,8	149,5	187,5	81,1	137,3	186,8	234,4				
	PREHEATING ³ (min)	156	90	66	52	156	90	66	52	160	93	68	54				
DHW FROM 10 TO 60 °C	LITRES 10' (L/10') ²	-	-	3038	3129	-	-	3999	4119	-	-	5127	5276				
	LITRES FIRST HOUR ²	-	-	4139	4684	-	-	5454	6172	-	-	6946	7843				
	CONTINUOUS DRAW (L) ³	-	-	1391	1965	-	-	1838	2594	-	-	2298	3242				
	POWER (kW)	-	-	81	114	-	-	107	151	-	-	134	189				
	PREHEATING ³ (min)	-	-	134	94	-	-	134	94	-	-	138	97				
NL ⁴	48				55				60								

(1) Volume of fluid contained in the heat exchanger

(2) Obtainable with pre-heated cylinder (at 45 °C with primary side set at 50 or 60 °C and pre-heated at 60 °C in the other cases) and a running heat source

(3) With a proper power heat source generator

(4) Primary side 80 °C - Secondary side 10-45 °C

BV2X - Lower heat exchanger powers with secondary side at 10/45 °C

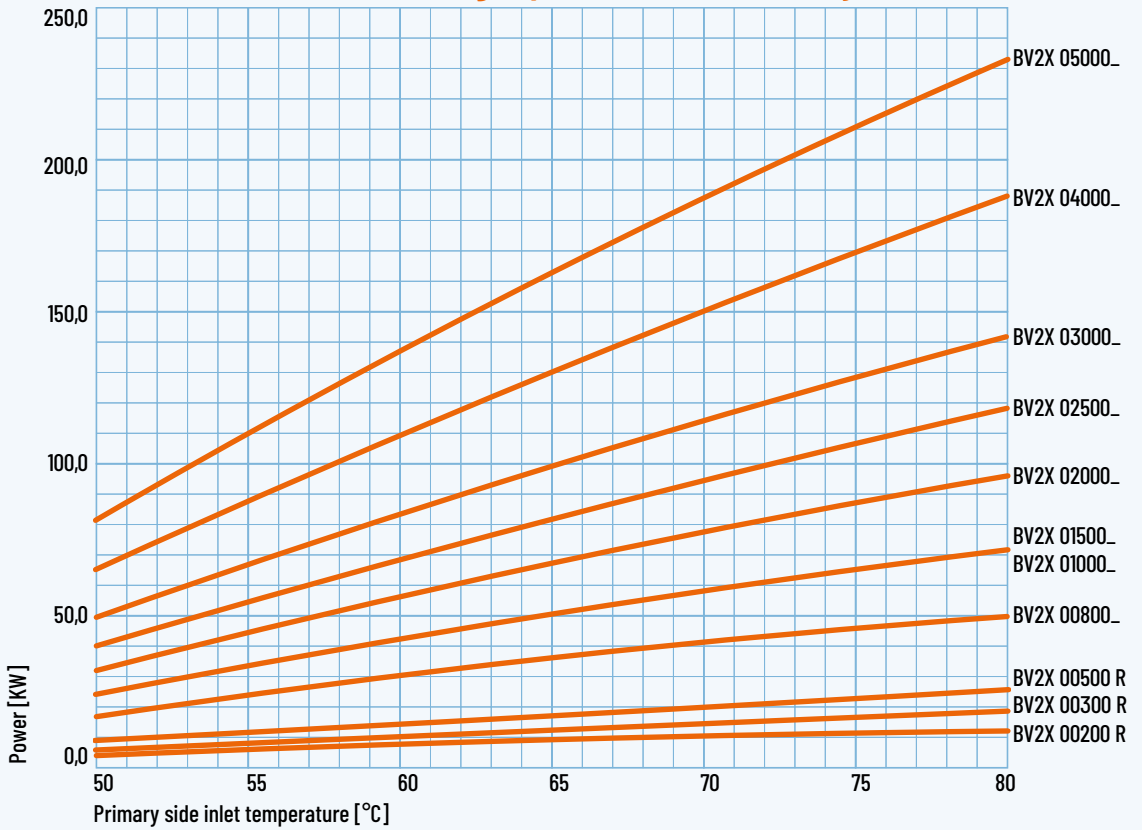

CALORIFIERS WITH
REMOVABLE HEAT
EXCHANGERS

BV2X - Lower heat exchanger pressure drops

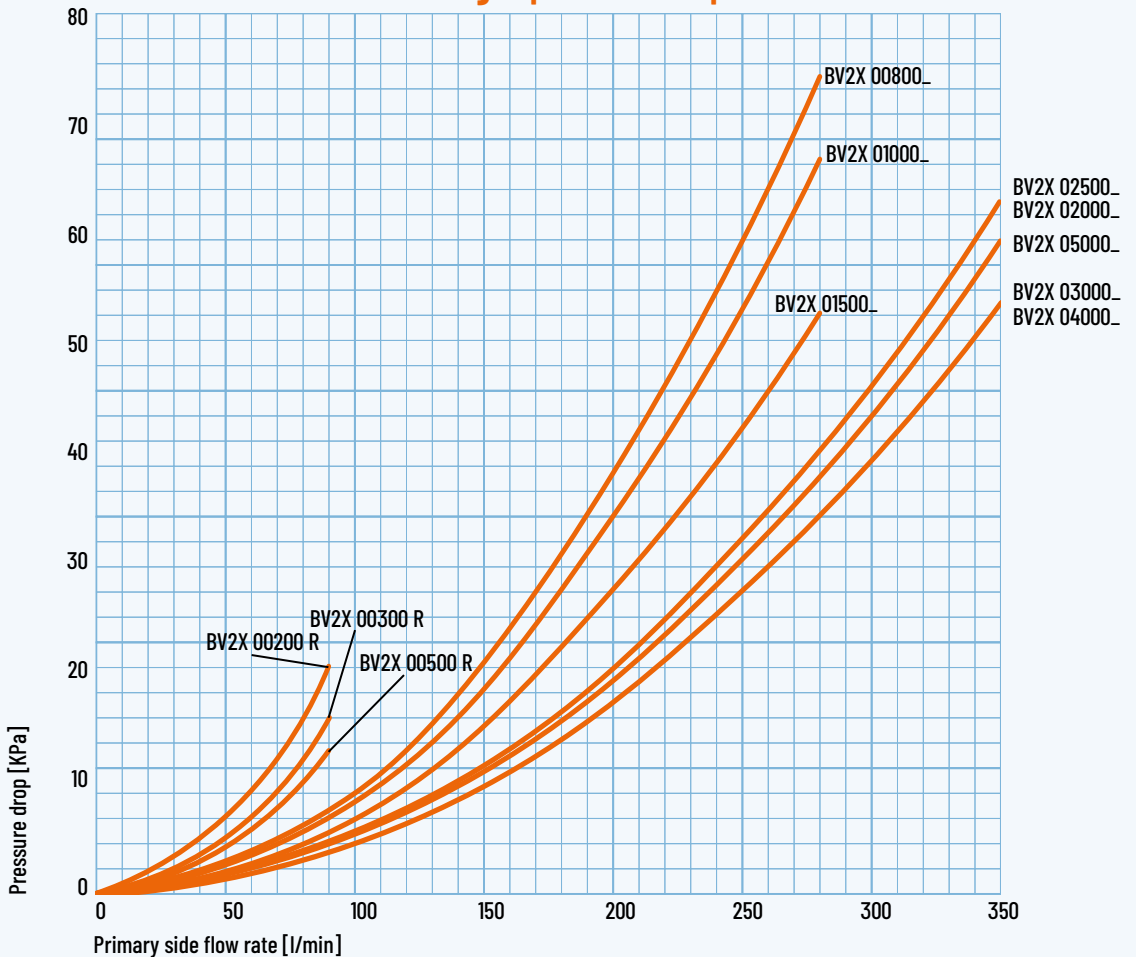



Data related to the upper heat exchanger

The performance values in the chart refer to the partial volume of water affected by the heat exchanger

MODEL		BV2X 00200 R				BV2X 00300 R				BV2X 00500 R				BV2X 00800_			
	HEAT EXCHANGER (m ²) [L] ¹	0,5 [2,9]				0,75 [3,8]				1,0 [4,7]				1,5 [7,7]			
	PRIMARY FLOW (m ³ /h)	2				2				3				4			
	PRIMARY TEMP. (°C)	50	60	70	80	50	60	70	80	50	60	70	80	50	60	70	80
DHW FROM 10 TO 45 °C	LITRES 10' (L/10') ²	142	154	219	229	196	213	302	317	324	347	492	512	511	546	775	805
	LITRES FIRST HOUR ²	225	297	414	474	319	423	588	677	488	628	1876	996	757	965	1347	1525
	CONTINUOUS DRAW (L) ³	105	180	246	310	155	264	361	455	208	355	485	611	310	529	723	909
	POWER (kW)	4,3	7,3	10,0	12,6	6,3	10,8	14,7	18,5	8,4	14,4	19,8	24,9	12,6	21,5	29,4	37,0
	PREHEATING ³ (min)	77	45	33	26	72	42	31	24	91	53	38	31	97	56	41	33
DHW FROM 10 TO 60 °C	LITRES 10' (L/10') ²	-	-	145	153	-	-	200	212	-	-	329	345	-	-	519	543
	LITRES FIRST HOUR ²	-	-	241	290	-	-	342	413	-	-	519	615	-	-	803	945
	CONTINUOUS DRAW (L) ³	-	-	121	173	-	-	179	254	-	-	240	341	-	-	358	508
	POWER (kW)	-	-	7	10	-	-	10	15	-	-	14	20	-	-	21	30
	PREHEATING ³ (min)	-	-	66	47	-	-	62	44	-	-	78	55	-	-	84	59
NL ⁴	0,9				2				5				11				
MODEL		BV2X 01000_				BV2X 01500_				BV2X 02000_				BV2X 02500_			
	HEAT EXCHANGER (m ²) [L] ¹	2,0 [9,5]				3,0 [13,0]				4,0 [17,2]				4,0 [17,2]			
	PRIMARY FLOW (m ³ /h)	5				6				7				7			
	PRIMARY TEMP. (°C)	50	60	70	80	50	60	70	80	50	60	70	80	50	60	70	80
DHW FROM 10 TO 45 °C	LITRES 10' (L/10') ²	572	618	876	915	916	984	1395	1453	1216	1305	1850	1925	1474	1563	2219	2294
	LITRES FIRST HOUR ²	898	1174	1636	1871	1399	1805	2516	2861	1854	2388	3326	3779	2113	2646	3696	4149
	CONTINUOUS DRAW (L) ³	412	702	960	1207	610	1038	1416	1779	807	1369	1865	2342	807	1368	1865	2342
	POWER (kW)	16,8	28,6	39,1	49,1	24,8	42,2	57,6	72,4	32,8	55,7	75,9	95,3	32,8	55,7	75,9	95,3
	PREHEATING ³ (min)	81	47	34	27	89	51	37	30	90	52	38	30	111	64	47	37
DHW FROM 10 TO 60 °C	LITRES 10' (L/10') ²	-	-	582	614	-	-	931	978	-	-	1235	1296	-	-	1494	1555
	LITRES FIRST HOUR ²	-	-	959	1148	-	-	1489	1767	-	-	1972	2338	-	-	2231	2596
	CONTINUOUS DRAW (L) ³	-	-	476	675	-	-	705	997	-	-	931	1315	-	-	931	1315
	POWER (kW)	-	-	28	39	-	-	41	58	-	-	54	76	-	-	54	76
	PREHEATING ³ (min)	-	-	69	49	-	-	76	53	-	-	77	54	-	-	95	67
NL ⁴	17				32				38				44				
MODEL		BV2X 03000_				BV2X 04000_				BV2X 05000_							
	HEAT EXCHANGER (m ²) [L] ¹	5,0 [20,8]				8,0 [31,4]				10,0 [34,3]							
	PRIMARY FLOW (m ³ /h)	10				12				15							
	PRIMARY TEMP. (°C)	50	60	70	80	50	60	70	80	50	60	70	80				
DHW FROM 10 TO 45 °C	LITRES 10' (L/10') ²	1769	1881	2670	2766	2387	2562	3630	3778	3028	3247	4602	4787				
	LITRES FIRST HOUR ²	2574	3250	4538	5113	3649	4698	6537	7425	4606	5916	8236	9346				
	CONTINUOUS DRAW (L) ³	1017	1729	2359	2965	1595	2698	3672	4607	1993	3372	4590	5758				
	POWER (kW)	41,4	70,4	96,0	120,7	64,9	109,8	149,5	187,5	81,1	137,3	186,8	234,4				
	PREHEATING ³ (min)	104	61	44	35	90	52	38	30	91	53	39	31				
DHW FROM 10 TO 60 °C	LITRES 10' (L/10') ²	-	-	1794	1871	-	-	2425	2545	-	-	3076	3226				
	LITRES FIRST HOUR ²	-	-	2723	3187	-	-	3881	4599	-	-	4896	5793				
	CONTINUOUS DRAW (L) ³	-	-	1174	1662	-	-	1839	2594	-	-	2298	3242				
	POWER (kW)	-	-	68	97	-	-	107	151	-	-	134	189				
	PREHEATING ³ (min)	-	-	90	63	-	-	77	54	-	-	79	55				
NL ⁴	48				55				60								

(1) Volume of fluid contained in the heat exchanger

(2) Obtainable with pre-heated cylinder (at 45 °C with primary side set at 50 or 60 °C and pre-heated at 60 °C in the other cases) and a running heat source

(3) With a proper power heat source generator

(4) Primary side 80 °C - Secondary side 10-45 °C

BV2X - Upper heat exchanger powers with secondary side at 10/45 °C

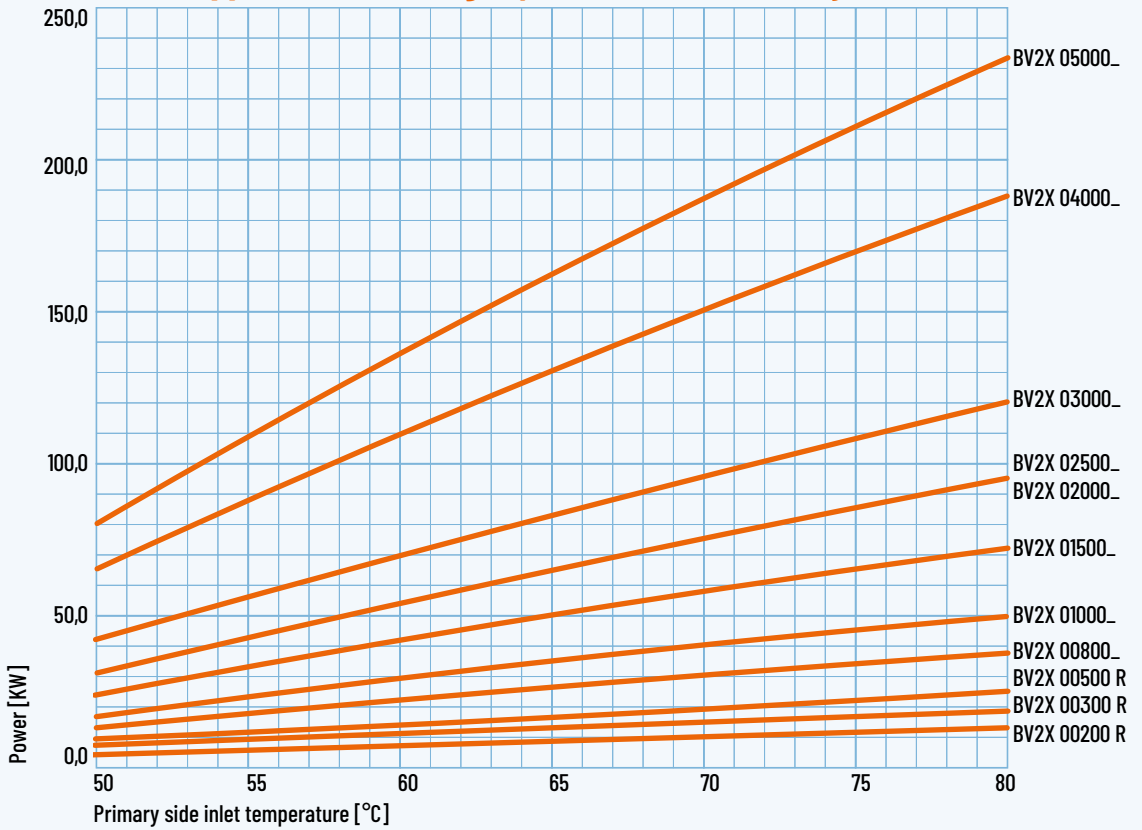

CALORIFIERS WITH
REMOVABLE HEAT
EXCHANGERS

BV2X - Upper heat exchanger pressure drops

